

Product Information

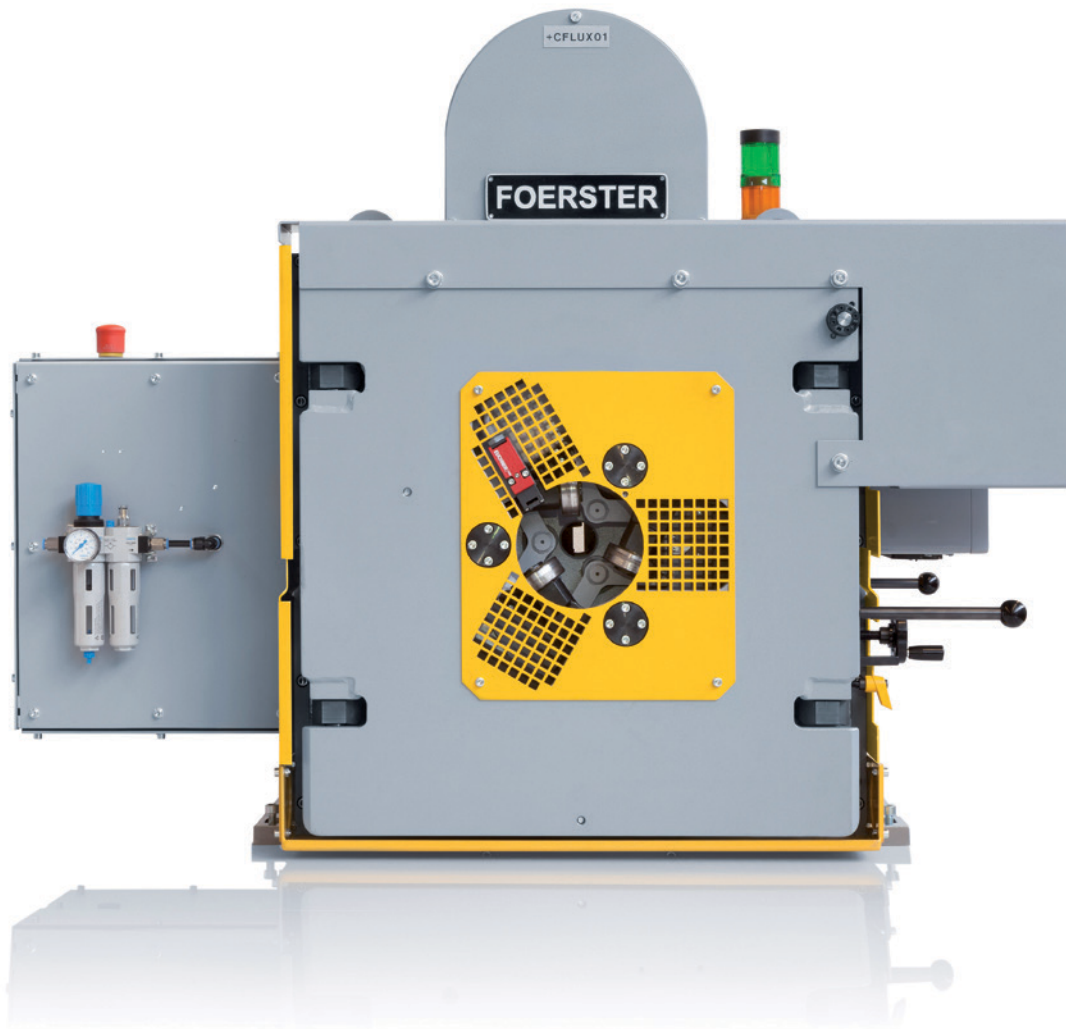

CIRCOFLUX® DS with Sensor Systems

Ro 75 / Ro 100 / Ro 130 / Ro 180
6.145



proof.

Index

Application	3
Operating Principle of the Flux Leakage Testing Method	4
Mechanical Construction	5
Testing and Evaluation Electronics	5
Sensor System	5
Rotor	6
Slip Ring and Brush Blocks	6
Rotating Inductive Transmitters	7
Rotating Disc	7
Test Lever	7
Test Head	8
Magnetizing Yoke	9
Automatic Dimension Adjustment	9
Rotating Head Electronics	10
Suction Connection	10
Roller Guides	11
Nozzles	11
Inner Roller Guide	12
Reference Bars	12
Technical Data	13
Specification of Test Material	14
Admissible Tolerance of Test Material	15
Flaw Testing	16
Flaw Detection Limit	16
Flaw Detection	16
Overview of Flaw Testing	16
Transportation Speed	17
Maximum Speed for Sensor Systems	18
Dimensions	19

Application

CIRCOFLUX testing systems are essential to achieve good quality in the production of round ferrous rolled bars for forging purposes. Here, the CIRCOFLUX testing system has become a must have for defect testing of metal surfaces and replaces subjective test methods like magnetic particle testing or the visual test.

The CIRCOFLUX sensor systems work with the Magnetic Flux Leakage method that is recommended in the European standard EN 10221 "Surface quality classes for hot-rolled bars and rods – Technical delivery conditions". The Alternating Field Magnetic Flux Leakage (MFL) is the most sensitive method to detect surface defects in hot-rolled ferrous bars. It ensures the detection of even the smallest longitudinal-oriented, crack-like defects. As a result, production errors can be detected at an early stage and the product quality can be significantly increased. There is one other advantage of the applied alternating current magnetization. No residual magnetism remains in the bar after testing and therefore eliminates the need of additional demagnetization.

CIRCOFLUX sensor systems Ro 75 / Ro 100 / Ro 130 / Ro 180 cover a material diameter range from approx. 10 mm to 180 mm.

Operating Principle of the Flux Leakage Testing Method

The CIRCOFLUX sensor system is based on the alternating field or AC Flux Leakage testing method using two rotating sensors. The test material is being contactlessly magnetized in the transverse direction by two encircling magnetization yokes through which an alternating current flows. The magnetic flux is concentrated on the material surface and is thus particularly sensitive for the detection of μm -sized surface defects from approx. 100 μm in depth. The distance between the yoke and the test material is a few millimeters. Between the yoke legs there are test shoes with protected probes that scan the surface with contact.

The intermittently operating probe only detects a very small part of the entire surface at any one moment. A very minor material defect thus produces a large disturbance in proportional terms. In the case of defect-free material, the magnetic flux produces a closed circuit in the material. Local inhomogeneities do not disturb the magnetic flux and are detected only as background noise.

The actual leakage flux results at exposed defects. The higher the frequency that the magnetization yoke is set, the closer to the surface the magnetization current flows (skin effect). At defects in the material, the magnetic flux can no longer flow unhindered and emerges from the material surface above the defect. This is referred to as leakage flux and can eventually be seen as a signal on the user interface.

In order to achieve uniform and complete surface testing with the sensor system, the rotational speed, number of probes and distance between them and the throughput speed of the test material have to match.

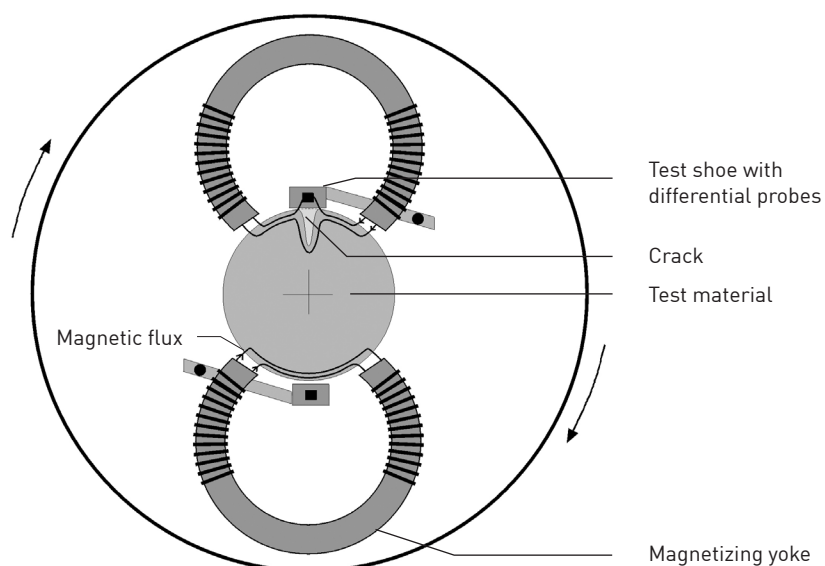

Fig 1: Magnetizing principle and Flux Leakage scanning

Mechanical Construction

In general a complete CIRCOFLUX test system consists of

- Testing and evaluation electronics
- Sensor system
- Cables and accessories

Testing and Evaluation Electronics

The testing and evaluation electronics consist of an Electronics cabinet (1) and a Power cabinet (2). The uniform hard- and software of the FOERSTER DS product platform as well as the integrated touch screen ensure easy handling.



Fig. 2: CIRCOFLUX® Testing and evaluation electronics

Sensor System

The CIRCOFLUX Sensor system is offered in four different sizes. They are used for a material diameter range of approx. 10 to 180 mm.

- **Sensor system Ro 75:** material diameter range 10 to 75 mm
- **Sensor system Ro 100:** [2 versions]: material diameter range 10 to 105 mm
- **Sensor system Ro 130:** material diameter range 15 to 130 mm
- **Sensor system Ro 180:** material diameter range 20 to 180 mm

The sensor system consists of the following main components:

Rotor

The rotor is bedded in a robust housing and is driven by a drive motor via a V-ribbed belt (1). The rotor consists of a hollow shaft (2) and the attached components.

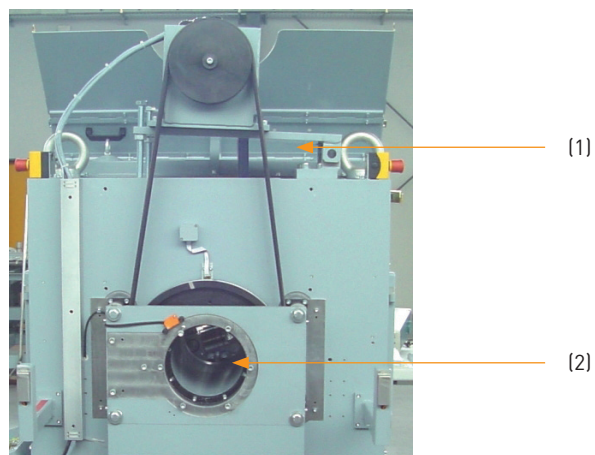

Fig 3: Rotor components

Slip Ring and Brush Blocks (only Ro 100 and Ro 180)

The slip ring is located on the bearing housing of the sensor system entry side. The slip ring tracks get into contact with all brush blocks.

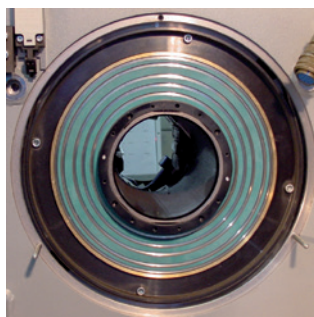

Fig 4: Slip ring at Ro 100

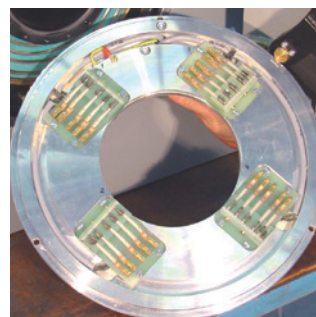

Fig 5: Brush block at Ro 100

Brush blocks with carbon brushes transmit the magnetization current of the slip ring.

Rotating Inductive Transmitters (only Ro 75 and Ro 130)

Feed the AC-field yokes and eliminate the insertion of slip ring and carbon brushes which need heavy maintenance.



Fig 6: Rotating inductive transmitters at Ro 130

Rotating Disc

The rotating disc for accommodating the test heads (1) is fitted on the front end of the hollow shaft. The probe levers (3a and 3b) on which the test heads are fitted are set using the central adjusting spindle (2).

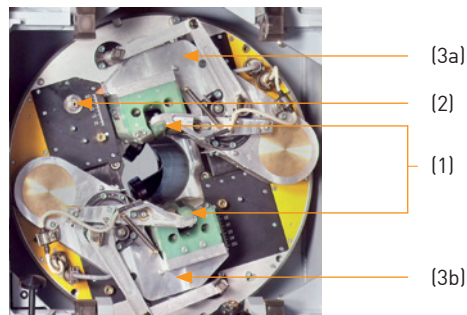

Fig 7: Rotating disc

Test Lever

The test lever is made of high-strength aluminium. The AC-field yoke is bolted rigidly to the test lever. By contrast to magnetizing without physical contact, the test piece surface is scanned with physical contact. The test lever is mounted so that it can swivel and is kept in the test position by means of a spring. It is thus protected against major damage resulting from impact on the yoke, e.g. as a result of incorrect adjustment or if unsuitable test material enters the system.

However, it must be ensured that the test lever is held reliably in the test position even during rotation. Consequently, the weight (1) ensures that the entire array mounted on the bearing bolt is in neutral equilibrium, i.e. the counterclockwise and clockwise torques resulting from the substantial centrifugal forces cancel each other.

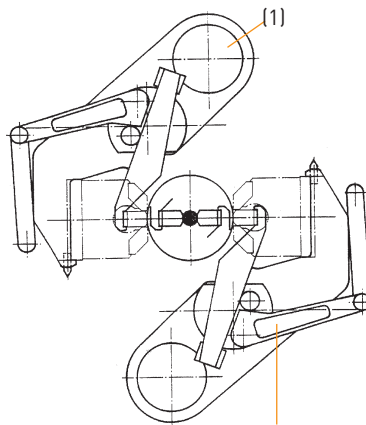

Fig 8: Adjustment of test levers

Test Head

The test head consists of a pivoted support frame and the test shoe with the probe unit (3) bolted onto the support frame. The contact faces of the test shoe housing have tungsten carbide protection strips. The entry and exit ends are protected by ceramic sliding strips. The support frame (2) consists of a high-strength aluminium milled component and it can rotate about one axis in the test lever. On the side opposite to the test shoe there is a counterweight (1) which is dimensioned such that the test head is mounted with slightly unilateral equilibrium. Consequently dependent upon the rotational speed of the rotating disc, the contact force of the test shoe on the test material surface is determined by the tension spring and the rotational speed. The extremely lightweight design of the support frame and test shoe guarantees the dynamic characteristics required for precise readjustment at high rotational speeds.

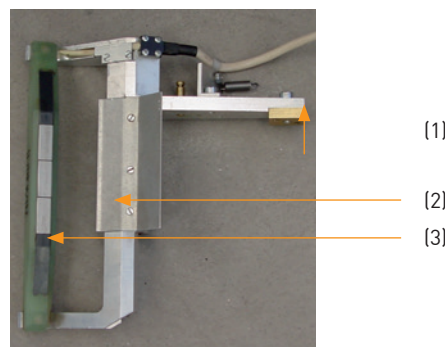

Fig 9: Test head

AC-Field Yoke

There are two AC-field yokes oppositely located in the rotating disc. The yokes are in a sturdy, dustproof housing. They have protective pressure pads (2) at the entry and exit ends, made of case-hardened steel, to protect against damage resulting from the test material. The magnetizing current is transferred via a connection cable (1) from the socket of the rotating disc to the yoke.

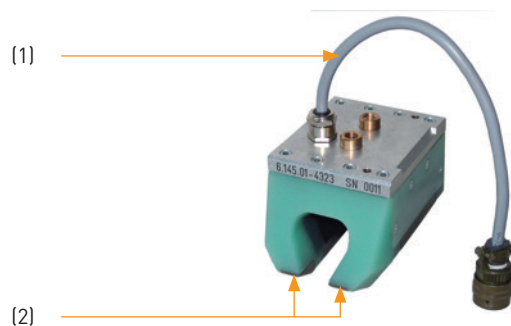

Fig 10: AC-Field Yoke

Automatic Dimension Adjustment (only Ro 100 and Ro 130)

Used in conjunction with a control unit in the power cabinet, this option enables the sensor system to be adjusted fully automatically to a required test piece diameter. This permits quick, reliable and accurate change of dimensions. The dimension control includes the adjustment of the testing lever in the rotating disc and the adjustment of the roller guides at the entry and exit side. The testing lever is adjusted externally if the rotating disc is stationary. The actuator of the rotating disc is flanged to the side of the rotating head (Fig 1). This option needs at least 6 bar compressed air. The roller guides are adjusted by a position unit mounted on the roller guide.

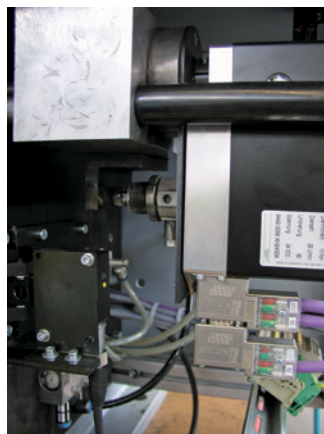

Fig. 11: Actuator of the rotating disc

Rotating Head Electronics

The sensor system transfers signals picked up by the probes to the test system for evaluation. The rotating head electronics (1) amplifies the sensor signals. It is accommodated in a robust box on the connection side of the bearing housing, allowing easy access for maintenance work.

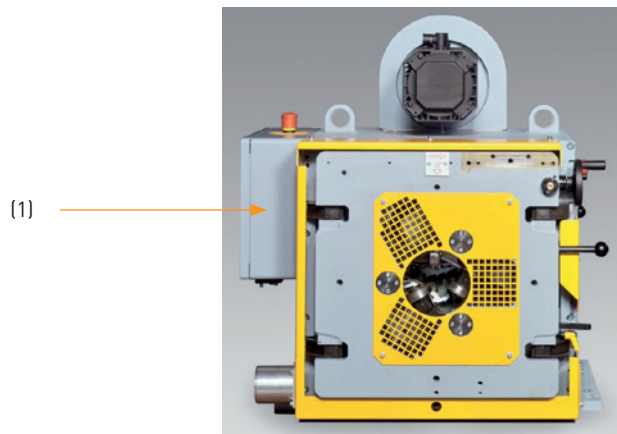

Fig 12: Rotating head electronics with emergency stop button

Suction Connection (only Ro 180)

In case of very harsh environmental conditions, a suction connection (1) can optionally be installed to collect dirt and scale. The dirt and scale is removed by means of a suction nozzle (2).

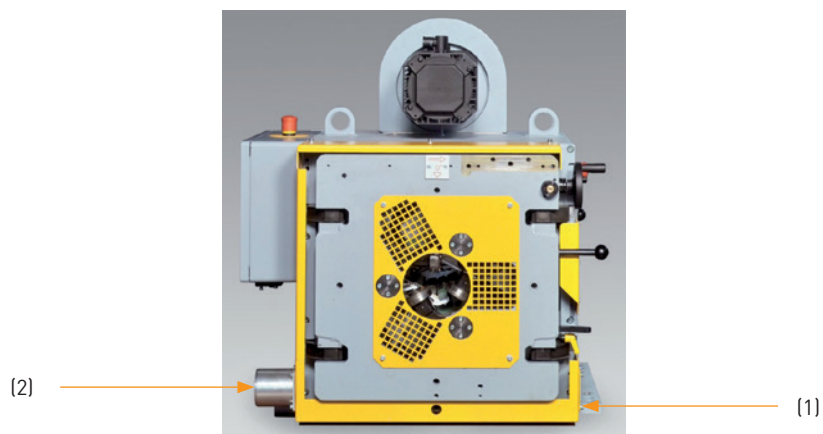

Fig 13: Suction connection

Roller Guides

Roller guides are fitted at the entry and exit sides of the sensor system for precise, vibration-free material guidance of the test material within the rotating unit. The roller guides must be adjusted to the relevant diameter of the test pieces for testing.

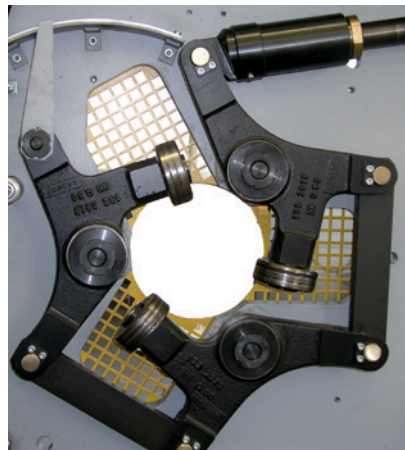

Fig 14: Roller guides

Nozzles (available for Ro 75 and Ro 100)

The nozzles can be used on well straightened material as an economical alternative to roller guides for test material diameter from 10 to 75 mm. The entry side nozzle guide can also be used in combination with roller guides as additional damage protection. The nozzle diameters are graded according to customer requirements. There is a compressed air connection option for the nozzle holders. Air jets in the nozzle housing direct jets of air to the test zone as required to keep the test heads clean and cool.



Fig 15: Nozzle holder, inner sleeve and nozzle

Inner Roller Guide (not compatible with nozzles)

Vibrations of passing test material may distort test results. To achieve a good guiding through the sensor system it is recommended for test material diameter ≤ 25 mm at Ro 75 / Ro 100 and for test material diameter ≤ 27 mm at Ro 130 to use the optional inner roller guide. The inner roller guide is mounted at the inlet end and protrudes into the hollow shaft.

Reference Bars

Reference bars with artificial defects are available for equipment setting and adjustment. The adjustment must be carried out when the rotating head is in the withdrawn position.

Length: 1200 mm

Diameter: 20 mm / 40 mm / 60 mm

Special nozzles for diameter 40 mm, which can be inserted in the nozzle holder, are available for the version with nozzles.

Technical Data

	Sensor system Ro 75	Sensor system Ro 100	Sensor system Ro 130	Sensor system Ro 180
Diameter range	10 - 75 mm Ø	10 - 100 mm Ø or 15 - 105 mm Ø	15 - 130 mm Ø	20 - 180 mm Ø
Maximum noise level	70 dB (A)			
Drive motor power	4.1 kW			7.5 kW
Variable rotational speed	0 - 2400 rpm	0 - 1500 rpm		0 - 960 rpm
Slow-down time with breaking (dependent on rotational speed)	approx. 60 seconds at maximum rotational speed			
Max. transportation speed (dependent on test material diameter and scanning track width of probes)	up to 4.8 m/s (for scanning track width 120 mm)	up to 3.75 m/s (for scanning track width 150 mm)	up to 4 m/s (for scanning track width 160 mm)	up to 2.4 m/s (for scanning track width 150 mm)
Set-up time with roller guides	approx. 3 minutes	approx. 3 minutes (with automatic dimension adjustment approx. 1.5 minutes)		approx. 5 minutes
Additional set-up time for inner roller guide	approx. 5 minutes			
Weight without roller guides	approx. 500 kg		approx. 850 kg	approx. 1900 kg
Dimensions (W x H x D) without roller guides	806 x 868 x 734 mm	807 x 868 x 756 mm	960 x 958 x 759 mm	1536 x 1485 x 1080 mm
Number of test heads	2			
Max. number of testing channels	8	12	24	12
Frequency of magnetizing current	7.5 kHz	6 kHz	7.5 kHz	6 kHz
Power consumption	4.2 kVA (230 V) or 7.5 kVA (400 V)			7.2 kVA (230 V) or 17 kVA (400 V)
Connection to electricity network	TN System			
With AOV rotating disc	0.1 L per adjustment (5 bar) of compressed air			

Specification of Test Material

	Specification of test material
Test material	Ferromagnetic steel bars or tubes with bright or hot-rolled round surface. The material has to be free from loose scales and chips. The ends of the test piece need to be free of burrs and with no deformation.
Surface	Blank, peeled or hot-rolled; Free from loose scale; Free from protruding burrs, peels, chips and pikes. Over- and underfills can cause pseudo-signals; Danger of damage if the prevalence is too high. Fluids and greases are not permitted for use.
Condition of the ends	Burr-free and parted perpendicular to the test axis; Without deformation of the cross-section.
Straightness tolerance	Max. 2 mm/m referred to the tangent, but not more than 10 mm over the total length of the test piece. Diameter tolerance: Accordance with DIN EN 10060 (± 0.5 to 1.0 mm, depending on diameter).
Diameter tolerance	According to DIN EN 10060; Deviation limit Precision P
Maximum Out-of-roundness	75 % of the diameter tolerance
Ambient temperature	5 °C to 45 °C
Maximum relative humidity	85 %
Temperature of test material	5 °C to 80 °C

Admissible Tolerance of Test Material

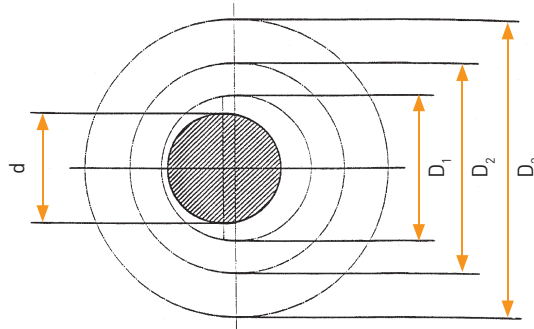

d [mm]	D ₁ [mm]	D ₂ [mm]	D ₃ [mm]
	Optimum test results can be anticipated if the test material lies within this tolerance limit.	Flaw detection may not be reliably reproducible if the test material lies within this tolerance limit.	Exceeding these limit values leads to damage or to destruction of the testing elements.
Nominal diameter of test material at Ro 75	Tolerance limits		Maximum limit
10 - 20	d + 0.2	d + 0.6	d + 6
20 - 40	d + 0.4	d + 1.2	d + 6
40 - 65	d + 0.7	d + 2.2	d + 6
65 - 75	d + 1.1	d + 3.3	d + 6
Nominal diameter of test material at Ro 100	Tolerance limits		Maximum limit
10 - 250	d + 0.2	d + 0.6	d + 8*
25 - 40	d + 0.4	d + 1.2	d + 18
40 - 65	d + 0.7	d + 2.2	d + 18
65 - 102	d + 1.1	d + 3.3	d + 18, but max. 115
Nominal diameter of test material at Ro 130	Tolerance limits		Maximum limit
15 - 27	d + 0.2	d + 0.6	d + 8*
27 - 40	d + 0.4	d + 1.2	d + 18
40 - 65	d + 0.7	d + 2.2	d + 18
65 - 130	d + 1.1	d + 3.3	d + 18, but max. 115
Nominal diameter of test material at Ro 180	Tolerance limits		Maximum limit
20 - 40	d + 0.4	d + 1.2	d + 8*
40 - 80	d + 0.7	d + 2.2	d + 18
80 - 180	d + 1.5	d + 4.5	d + 18

Deviation of the test material at the point of inspection resulting from center deviation, material tolerances and curvature etc. is permissible, as long as every point on the test material surface remains within a given tolerance range. Protrusions (e.g. burrs) can cause damage to the AC-yokes even if the test limits are met.
 * Limitation by inner roller guide

Flaw Testing

Flaw Detection Limit

The limit is dependent on the interference level. This level is influenced by the surface of the test material, by surface roughness, as well as guiding and transportation. Flaw detection in areas featuring burrs, overfills, collapsed points or others is not reliably reproducible, or is limited to a great extent. Pseudo-signals can not be excluded depending on the type of the protruding part. A satisfactory result is to be expected if the test part is within the circle diameter D_1 or max. D_2 (see page 15).

Flaw Detection

The CIRCOFLUX test system is suitable for the detection of longitudinal test grooves in the outer surface of hot-rolled round material (depending on the straightness).

- Test defect: **Depth 0.15 mm**
Width 0.15 mm
- Reproducible minimum flaw length at 100% test (3 dB reproducibility):
 - 15 mm of test shoe x 12.5 mm sensors or 18.7 mm
 - 12.5 mm of test shoe x 10 mm sensors or 15.0 mm
 - 10 mm of test shoe x 7.5 mm sensors or 11.2 mm
- Formula for calculation of the minimum flaw length:
 - DKD:** Probe distance + 2.5 mm
 - DIP-ARRAY:** Probe distance x 1.5

A better result is possible in many cases. For this purpose, however, tests must be carried out on representative customer material.

Overview of Flaw Testing

Flaw type	Longitudinal surface defects
Flaw detection	Test flaws with a depth from 0.1 mm may be detected, dependent upon surface roughness.
Reproducibility	≤ 3 dB of flaw signals
Untested Ends	Deburred, straight and right-angled cutted ends, constant test speed and untraceability of the test part <50 mm

Transportation Speed

Explanation of the speed table (see page 18):

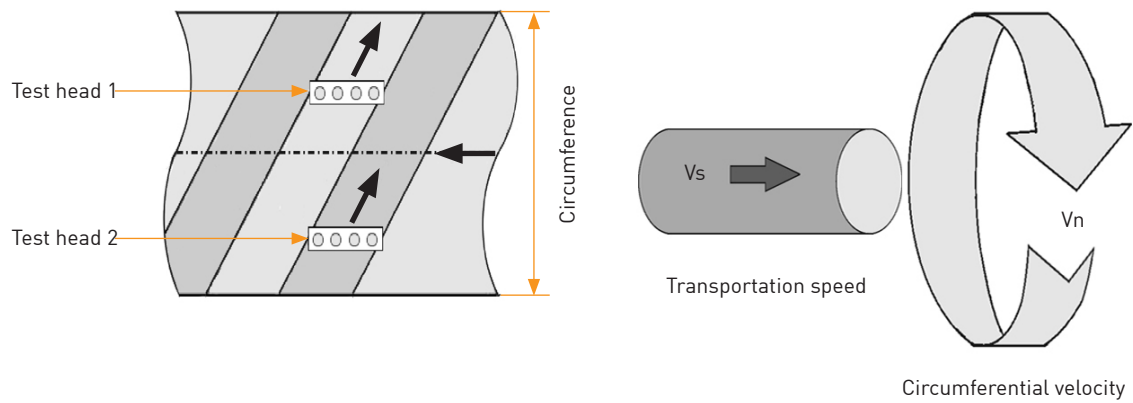

Maximum Speed for Sensor Systems

(the values shown are nominal values)

Ro 75 with scanning track width $g = 120$ mm

D [mm]	$V_{s_{max}}$ [m/s]	n [1/min]	Vn [m/s]
10	4.80	2400	1.26
20	4.80	2400	2.51
30	4.80	2400	3.77
40	4.77	2387	5.00
50	3.82	1910	5.00
60	3.18	1592	5.00
70	2.73	1364	5.00
75	2.55	1273	5.00

Ro 100 with scanning track width $g = 150$ mm

D [mm]	$V_{s_{max}}$ [m/s]	n [1/min]	Vn [m/s]
20	3.75	1500	1.57
30	3.75	1500	2.36
40	3.75	1500	3.14
50	3.75	1500	3.93
60	3.75	1500	4.71
70	3.41	1364	5.00
80	2.98	1194	5.00
90	2.65	1061	5.00
100	2.39	955	5.00

Ro 130 with scanning track width $g = 160$ mm

D [mm]	$V_{s_{max}}$ [m/s]	n [1/min]	Vn [m/s]
20	4.00	1500	1.57
30	4.00	1500	2.36
40	4.00	1500	3.14
50	4.00	1500	3.93
60	4.00	1500	4.71
70	3.64	1364	5.00
80	3.18	1194	5.00
90	2.83	1061	5.00
100	2.55	955	5.00
110	2.31	868	5.00
120	2.12	796	5.00
130	1.96	735	5.00

Ro 180 with scanning track width $g = 150$ mm

D [mm]	$V_{s_{max}}$ [m/s]	n [1/min]	Vn [m/s]
20	2.40	960	1.01
30	2.40	960	1.51
40	2.40	960	2.01
50	2.40	960	2.51
60	2.40	960	3.02
70	2.40	960	3.52
80	2.40	960	4.02
90	2.40	960	4.52
100	2.39	955	5.00
110	2.17	868	5.00
120	1.99	796	5.00
130	1.84	735	5.00
140	1.71	682	5.00
150	1.59	637	5.00
160	1.49	597	5.00
170	1.40	562	5.00
180	1.33	531	5.00

For continuous testing, rotation speed and line speed tolerances are used for a worst-case calculation in the active test mode. This can lead to the throughput speeds being approx. 5 % below the nominal values.

Dimensions

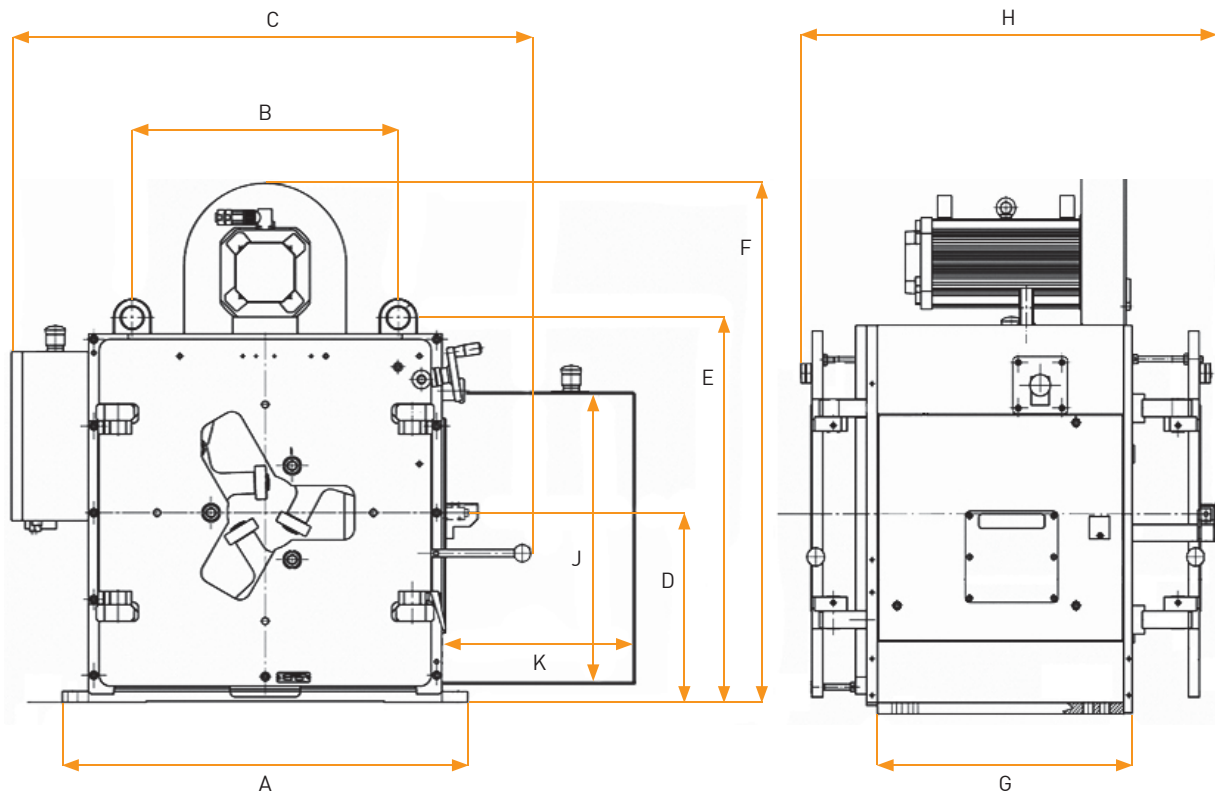

Size [mm]	Sensor system			
	Ro 75	Ro 100	Ro 130	Ro 180
A	580	580	750	1106
B	470	470	492	840
C	811	811	960	1536
D	300	300	350	500
E	625	625	710	1069
F	868	868	958	1485
G	435	435	450	850
H	734	756	759	1080
J	-	439	439	-
K	-	331	331	-

Worldwide Sales and Support Offices



Headquarters

- Institut Dr. Foerster GmbH & Co. KG, Germany

Subsidiaries

- Magnetische Pruefanlagen GmbH, Germany
- FOERSTER France SAS, France
- FOERSTER U.K. Limited, United Kingdom
- FOERSTER Italia S.r.l., Italy
- FOERSTER Russland AO, Russia
- FOERSTER Tecom s.r.o., Czech Republic
- FOERSTER (Shanghai) NDT Instruments Co., Ltd., China
- FOERSTER Japan Co., Ltd., Japan
- NDT Instruments Pte Ltd, Singapore
- FOERSTER Instruments Inc., USA

The FOERSTER Group is being represented by subsidiaries and representatives in over 60 countries - worldwide.

Institut Dr. Foerster GmbH & Co. KG Division Test Systems

In Laisen 70
72766 Reutlingen
Germany
+49 7121 140 0
info@foerstergroup.de

