

Simplify Complex Microscope-Based Manufacturing Tasks

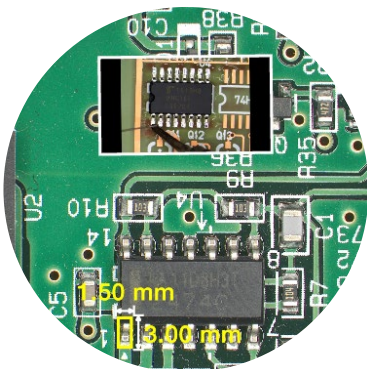

Transform How You Work

The AR1 microscope system enables you to overlay text and digital images over your microscope's field of view, making it easy for assemblers to follow directions, read notes, and even watch videos without removing their eyes from the oculars. The AR1 module works with Evident SZX series stereo microscopes, turning them into augmented reality tools that improve the speed and efficiency of your microscope-based manufacturing tasks as well as training new users.

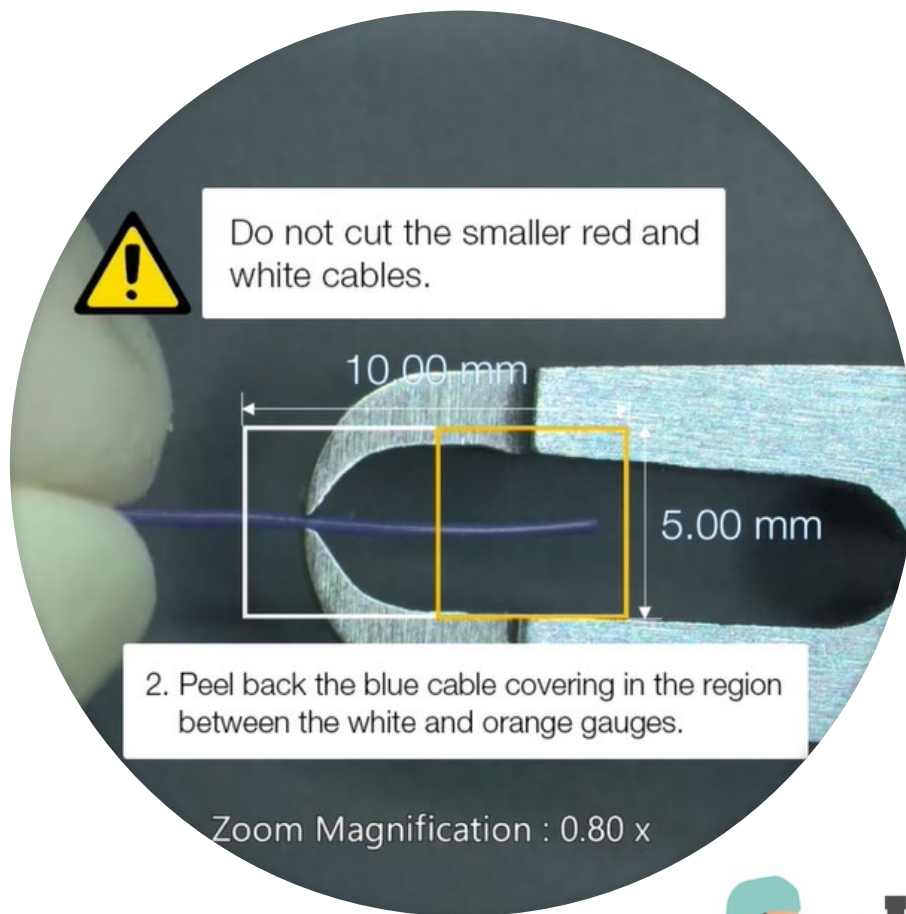

Faster, More Efficient Assembly Process

Reduce the Risk of Human Error

During complex manufacturing tasks, the ability to project assembly instructions, procedure manuals, images, a digital reticle, measurement gauge, or notes into a microscope's field of view can help assemblers complete their work with fewer mistakes.

In a typical manufacturing setting, an assembler may need to repeatedly take their eyes away from the microscope to check assembly instructions or memorize these instructions before beginning their work. Both methods are inefficient and can result in errors. The AR1 system's projection technology enables directions for each step to be projected onto the sample as the user moves through the assembly. This can reduce the chance of memorization errors and enable the operator to remain more comfortable while they're working since they can stay focused on their task instead of repeatedly having to look away.

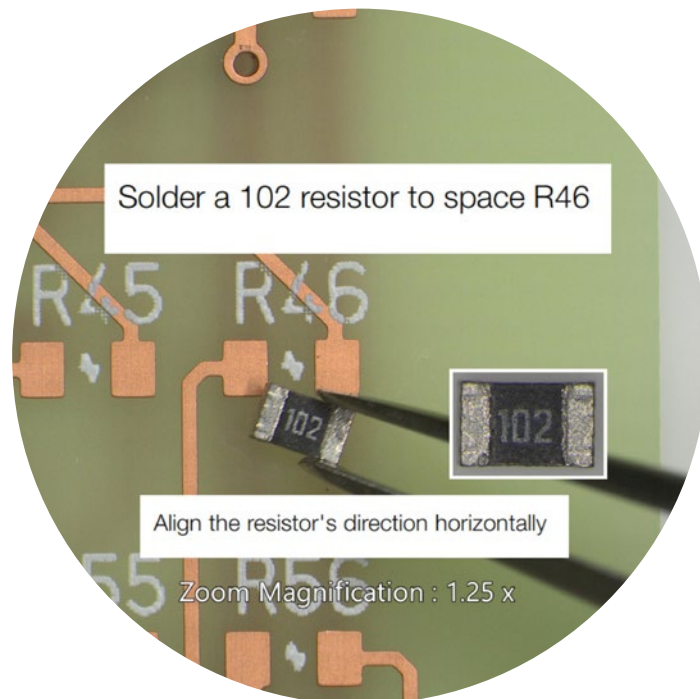

Keep Your Manufacturing Line Moving

Simple-to-use AR1 software makes it easy for production engineers to quickly set up the program the operator will use during the assembly, making the system easy to onboard and integrate into your manufacturing process.

If an assembler encounters an issue during their work, the AR1 system can be used with third-party collaboration software—like Microsoft Teams—to enable an offsite manager or engineer to view the microscope's field of view to provide remote guidance. The offsite manager can guide the assembler through the issue in real time to overcome problems quickly and keep the manufacturing line moving. If anything needs to be documented, the system's image and video recording features make this fast and simple.

Get New Employees Up to Speed Fast

Efficiently Train Employees

Training employees on the manufacturing line can be time consuming and expensive. The AR1 system makes your training more efficient and flexible.

In a conventional training workflow, an on-site trainer instructs a new employee about each step of the assembly process and shows how components should look when they're properly assembled. The trainee must look away from the eyepieces to see what the trainer is talking about and then look back at the sample under their microscope. With the AR1 system, a user can receive training while they keep their eyes on the eyepieces, enabling them to stay focused.

Training without Travel

If trainers need to travel to different locations, this adds time and cost to the process. With the AR1 system, the trainer can conduct their work remotely without having to travel. This is more efficient and eliminates travel expenses, making it cost effective.

The AR1 system also makes it possible to use video recordings to train new employees rather than a live trainer as instructions can be projected directly onto the sample through the microscope's field of view.

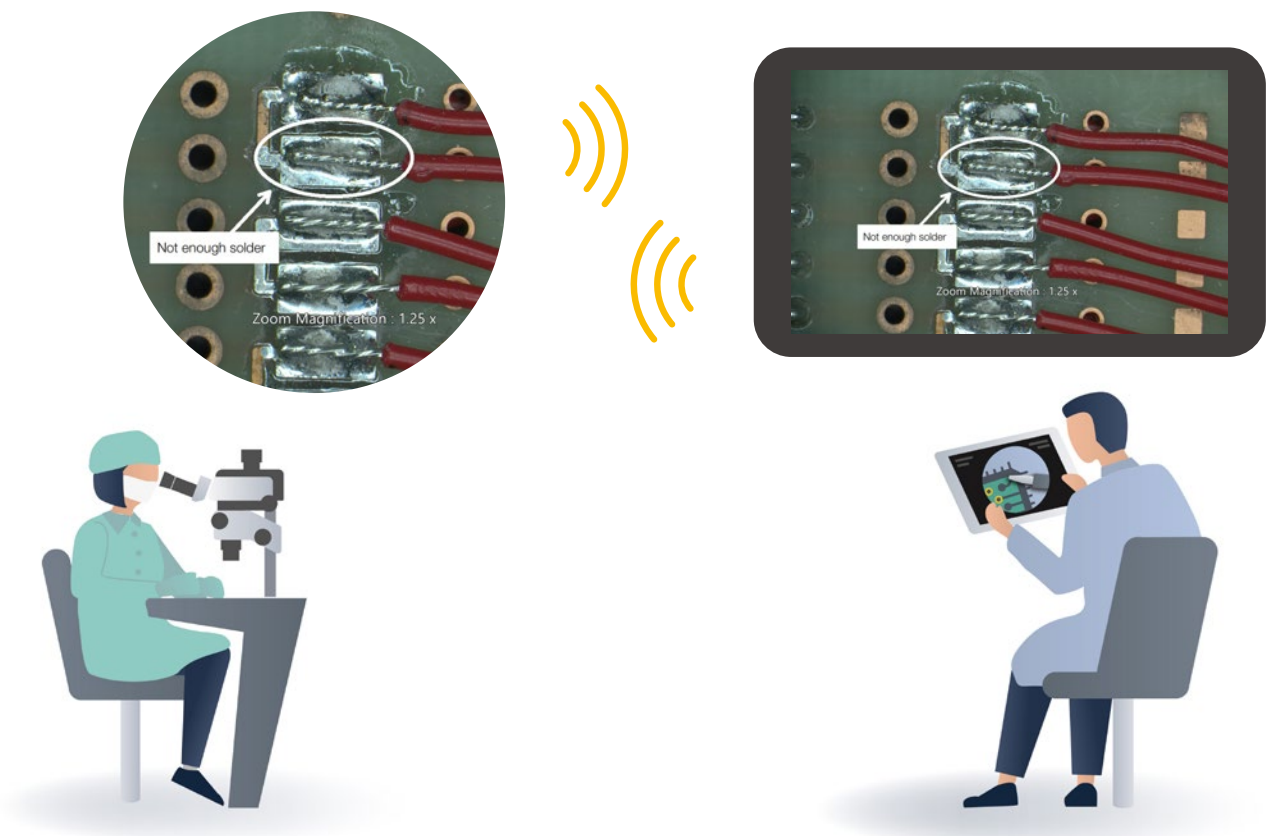

Works Seamlessly with Your Existing Stereo Microscopes

Minimal Effort and Cost to Onboard

With an easy-to-implement design, the AR1 system attaches easily to most SZX stereo microscopes. Simply replace the tilting trinocular, and the SZX-AR1 module mounts directly to the system.



Stay Comfortable while Working

Evident offers a variety of ergonomic components for stereo microscopes that enable you to remain comfortable while you work. The ergonomic tilting trinocular tube and eyepoint adjuster enable users to adjust the microscope so that they can maintain a comfortable, natural posture while they're working.



Tilting trinocular tube

Efficient Production and Training

The AR1 system improves the efficiency of your production line and user training.

Production line

Stay comfortable while you work. Ergonomic components enable you to adjust the tilt angle from 5 to 45 degrees and the eyepoint height within a 120 mm (4.7 in.) range.



The zoom magnification sensor tracks the magnification in the software, enabling you to set a defined magnification without taking your eyes away from the eyepieces to check.



Preparation

Create an assembly manual using the AR1 software and use it on a PC that has the AR1 software installed.



Open and project the assembly manual into the microscope's field of view.



During assembly, you can keep your eyes in the eyepieces, reducing eye movement and errors caused by memorization mistakes.

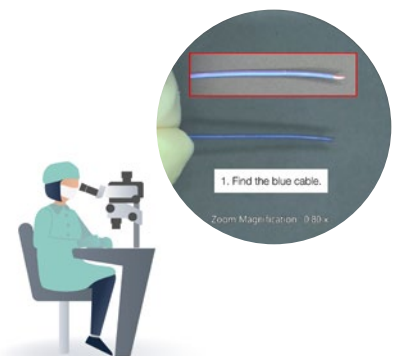

Instructions are projected directly in the field of view. You can draw lines, arrows, rectangles, and add text to document what you see or get help from an offsite manager.

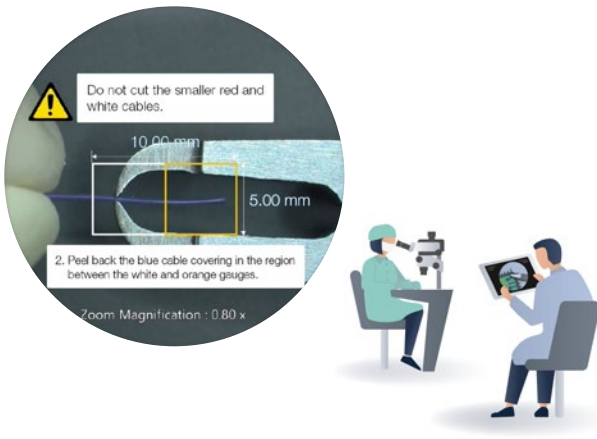

Project a zoom-linked digital gauge, reticle, and grid in the field of view, reducing the need for manual operations.

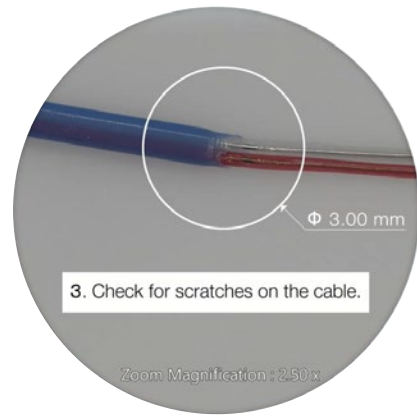

Assembly Process

Move forward and backward through the projected manual using buttons on the zoom magnification sensor or a third-party footswitch, so you can leave your hands on the microscope.



Record images and movies of the assembly process for analysis or record keeping.



Training

Stay comfortable while you work. Ergonomic components enable you to adjust the tilt angle from 5 to 45 degrees and the eyepoint height within a 120 mm (4.7 in.) range.



A trainer and trainee can be connected using a remote communication tool—like Microsoft Teams—reducing the need for the trainer to travel.

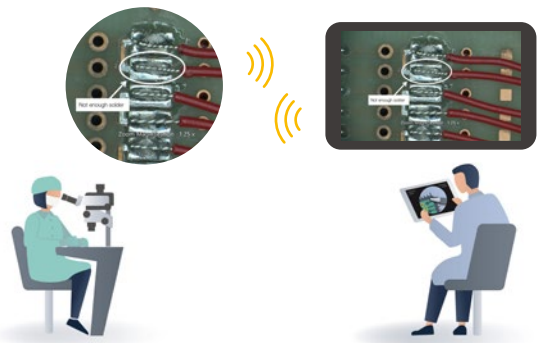

Preparation

Training

A trainer can use a digital pointer in the field of view to highlight the trainee's work and clearly explain how a component is assembled.

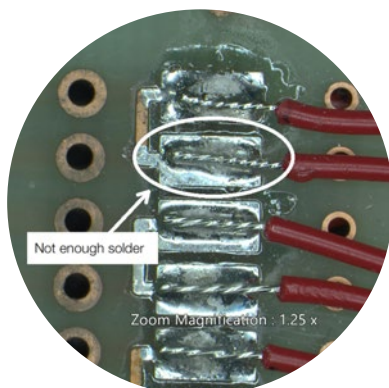

A self-training video can be projected in the field of view to reduce the teaching burden on the trainer.

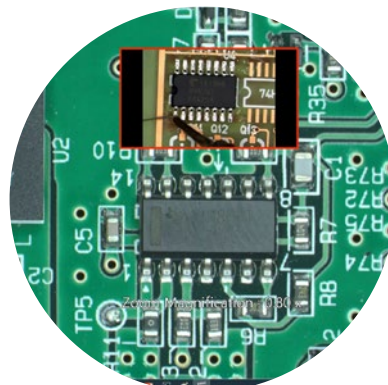

SZX-AR1 System : when combined with the SZX-ZB7

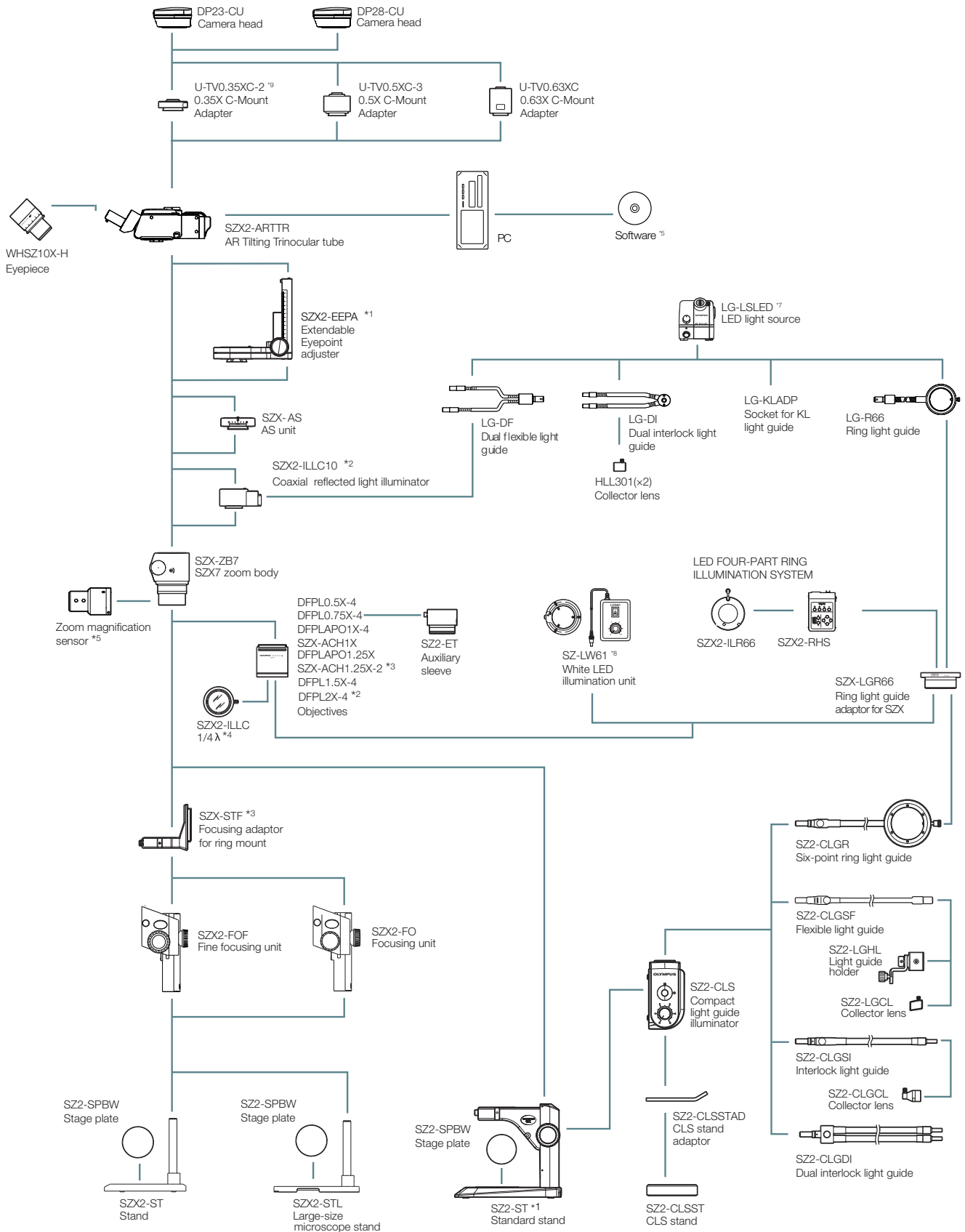

NOTES :

- *1 SZX2-EEPA and SZ2-ST cannot be combined.
- *2 SZX2-ILLC10 and DFPL2X-4 cannot be combined.
- *3 SZX-ACH1.25X and SZX-STF cannot be combined.
- *4 Attached to SZX2-ILLC10.
- *5 Attached to SZX2-ARTTR.
- *6 Product performance cannot be guaranteed if units other than those listed in this system chart are combined.
- *7 Different LED light sources are available in different regions.
- *8 Not available in some areas.
- *9 Ghosting may appear at the edges of images when they're captured using the U-TV0.35XC camera adaptor combined with the SZX-Z7B or SZX2-ZB10 zoom bodies and the extendable eyepoint adjuster is set to a height of 100 mm or more.

SZX-AR1 System : when combined with the SZX2-ZB10

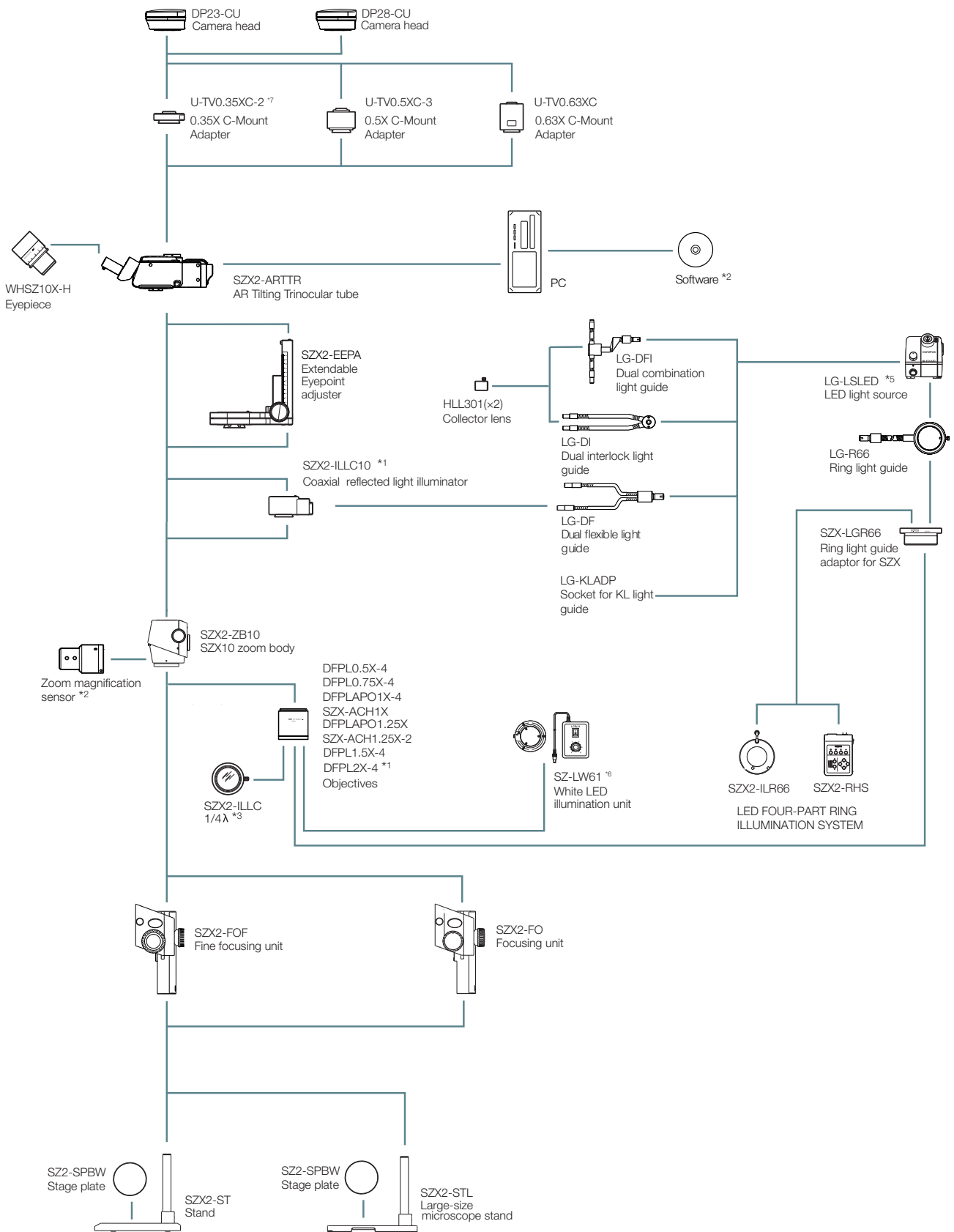

NOTES :

*1 SZX2-ILLC10 and DFPL2X-4 cannot be combined.

*2 Attached to SZX2-ARTTR.

*3 Attached to SZX2-ILLC10.

*4 Product performance cannot be guaranteed if units other than those listed in this system chart are combined.

*5 Several LED light sources are offered in some regions.

*6 Not available in some areas.

*7 Ghosting may appear on the edges of images captured with the camera when the camera adapter U-TV0.35XC is combined with the zoom microscope body SZX-Z7B or SZX2-ZB10 and the extendable eyepoint adjuster function is being used at a height of 100mm or more.

SZX-AR1 System : when combined with the SZX2-ZB16

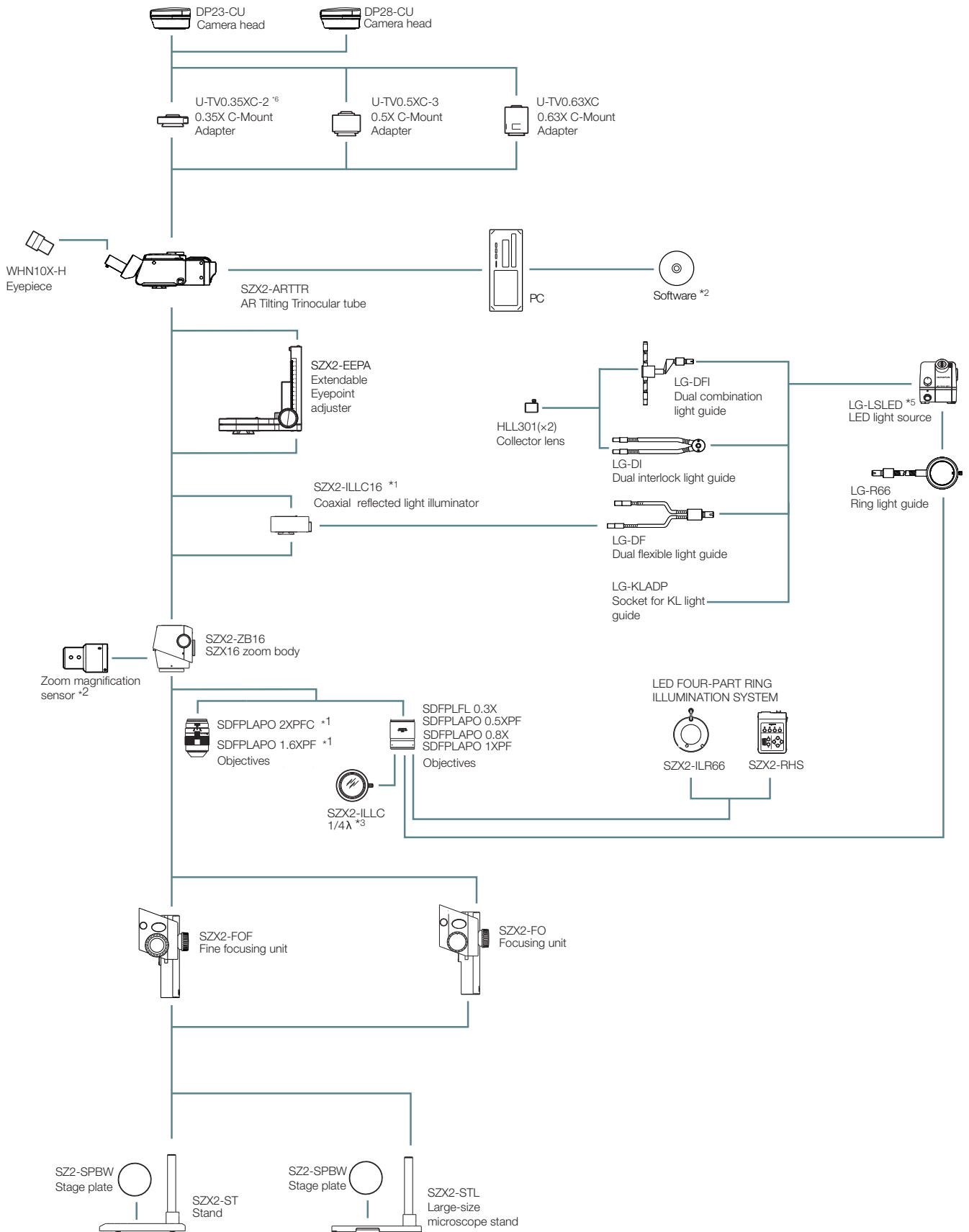

NOTES :

- *1 SZX2-ILLC16 and SDFPLAPO 1.6XPF / 2XPFC cannot be combined.
- *2 Attached to SZX2-ARTTR.
- *3 Attached to SZX2-ILLC16.
- *4 Product performance cannot be guaranteed if units other than those listed in this system chart are combined.

*5 Several LED light sources are offered in some regions.

*6 Ghosting may appear at the edges of images when they're captured using the U-TVO.35XC camera adaptor combined with the SZX-Z7B or SZX2-ZB10 zoom bodies and the extendable eyepoint adjuster is set to a height of 100 mm or more.

Specifications

Hardware

AR tilting trinocular tube SZX2-ARTTR	Angle of observation tube: 5 to 45 degrees
	Interpupillary distance adjustment range: 57 to 80 mm
	Equipped with eyepiece clamping knob
	Light-path switching mechanism: None
	Magnification of eyepiece: 1.25X, magnification of camera: 1X
	Functions of buttons on the front panel: AR image brightness adjustment (7 levels) and AR image ON/OFF
	Input connectors: HDMI x 1, USB 2.0 (Type-C) x 1, DC jack x 1
Zoom magnification sensor	Drive voltage: AC 100-240 V (AC adaptor)
	Maximum power consumption: 10 W
	Main Functions: (a) Get the zoom magnification (at click position only) (b) Forward and backward the slides created on software
Operating environment	Output connector: USB 2.0 (Type-C)
	Ambient temperature: 10 to 35 °C (50 to 95 °F)
	Relative humidity: 0 to 85%
	Supply voltage fluctuation: ±10%
	Pollution degree: 2 (in accordance with IEC60664-1)
Conditions for safety standards	Installation/overvoltage category: II (in accordance with IEC60664-1)
	Tilt of stand: ±3° or less
	Indoor use
	Altitude: Max. 2000 meters (6562 ft)
Operating method	Temperature: 5 to 40 °C (41 to 104 °F)
	Relative humidity: 20 to 80% (31 °C (87.8 °F) or less) (without condensation)
	If over 31 °C (87.8 °F), the relative humidity in the operating environment is decreased linearly through 70% at 34 °C (93.2 °F), 60% at 37 °C (98.6 °F), and to 50% at 40 °C (104 °F).
	Do not move the product while in use
Relocation and transportation method	Storage after use is not assumed
	Repack the product with packing materials before transportation
	Users are not authorized to relocate the instrument

Software

Camera control function	Exposure control: Switching between Auto and Manual
	ISO sensitivity adjustment: ISO100, 200, 400
Acquisition function	White balance adjustment function: Equipped (one-touch adjustment)
	Snapshot acquisition
	Save format: BMP, JPEG, PNG
	Resolution: DP23: 3088 × 2076, DP28 :4104 × 2174
	The camera image can be saved with the AR image simultaneously
	Recording
	File saving formats: mp4, mov; Video codec: H264
	Audio format: MP3; Audio codec: mp3
	Resolution: DP23: 1920 × 1080 (camera image range: 1600 × 1080), DP28: 1920 × 1080 (camera image range: 1920 × 1080)
	The video cannot be recorded out of the camera image range
Barcode function	The camera image can be saved with the AR image simultaneously
	The recording time is approximately one hour
	The SZX-AR1 software can generate a QR code linked to the procedure.
	The QR code can be scanned with a barcode reader to recall the procedure in the eyepiece field of view.
	Compatible barcode reader
	COM communication is available
Software language	A QR code can be loaded
	Output barcode: QR code
	English, Japanese, Chinese, German, Spanish, Portuguese, French

PC requirements

· The PC used with this system should conform to IEC/EN60950-1 or IEC/EN62368-1

· The system requirements for the PC used with this system are listed below; even if the PC is used in the recommended operating environment, it does not guarantee that all functions will work on all commercially available PCs.

OS	Windows 10 Pro (64-bit), Windows 10 pro for Workstation (64-bit)
	Windows 10 version: 2004, 21H1
OS language	Windows 10 IoT Enterprise LTSC 2019 (combined with a DP23 or a DP28)
Processor	English, Japanese
Memory	10th Gen Intel® Core™ i5 or later (or equivalent)
Storage capacity to install software	(Recommended core: 4 or more, clock frequency: 3.2 GHz)
Graphic controller	8 GB or more
Monitor resolution	1 GB or more
USB interface	Intel UHD Graphics 630 or higher
	USB 2.0 Type-A x1 (for connecting to the AR tilting trinocular tube)
	USB 2.0 Type-A x1 (for the zoom magnification sensor)
Monitor interface	USB 3.1 Type-A x1 (for a DP23 and a DP28 camera)
	HDMI x1 (for connecting to the AR tilting trinocular tube)
	HDMI 1.4 or more
	HDMI connector: Type-A

- EVIDENT CORPORATION is ISO14001 certified.
- EVIDENT CORPORATION is ISO9001 certified.

- All company and product names are registered trademarks and/or trademarks of their respective owners.
- Images on the PC monitors are simulated.
- Illumination devices for microscope have suggested lifetimes. Periodic inspections are required. Please visit our web site for details.
- Specifications and appearances are subject to change without any notice or obligation on the part of the manufacturer.

EvidentScientific.com



EVIDENT CORPORATION
Shinjuku Monolith, 2-3-1 Nishi-Shinjuku, Shinjuku-ku, Tokyo 163-0910, Japan

N8602558-042022